

Photomicrosensor

EE-SPX/
EE-SPY

Light Modulation Effectively Reduces External Light Interference

- Easy adjustment and optical axis monitoring with a Light-ON indicator.
- Wide operating voltage range (5 to 24 VDC) makes smooth connection possible with programmable controllers (PC).
- Easy-to-wire connector assures ease of maintenance.
- Fitted with an easy-to-adjust optical axis mark.

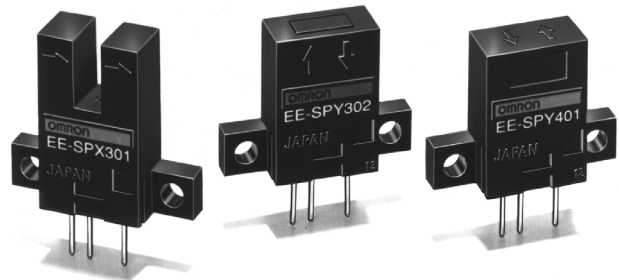

Ordering Information

Appearance	Sensing method	Sensing distance	Output configuration	Model	Weight
	Transmissive-type (channel-type)	3.6 mm (channel width)	Light-OFF	EE-SPX301	Approx. 2.6 g
			Light-ON	EE-SPX401	
	Reflective type	5 mm	Light-OFF	EE-SPY302	
			Light-ON	EE-SPY402	
	Reflective type	5 mm	Light-OFF	EE-SPY301	
			Light-ON	EE-SPY401	

Specifications

■ Ratings

Item	Transmissive-type (channel-type)	Reflective
	EE-SPX301, EE-SPX401	EE-SPY301, EE-SPY401, EE-SPY302, EE-SPY402
Supply voltage	5 to 24 VDC $\pm 10\%$, ripple (p-p): 5% max.	
Current consumption	Average: 15 mA max.; Peak: 50 mA max.	
Rated sensing distance	3.6 mm (channel width)	5 mm (Reflection factor: 90%; white paper: 15 × 15 mm) (see note 3)
Standard reference object	Opaque: 0.5 × 1 mm ² min.	Transparent and opaque
Differential distance	0.05 mm max.	0.2 mm (with a sensing distance of 3 mm, horizontally)
Control output	At 5 to 24 VDC: 80-mA load current (I_C) with a residual voltage of 1.0 V max. 10-mA load current (I_C) with a residual voltage of 0.4 V max.	
Indicator (see note 1)	Light indicator (red)	
Response frequency (see note 2)	500 Hz	100 Hz
Connecting method	Dedicated connectors: EE-1002, EE-1003 (with 1 m cable attached) (soldering not possible)	
Light source	GaAs infrared LED (pulse lighting) with a peak wavelength of 940 nm	
Receiver	Si photo-diode with a sensing wavelength of 850 nm max.	

- Note:** 1. The indicator is a GaP red LED (peak emission wavelength: 700 nm).
2. The response frequency was measured by detecting the following Disks rotating.

EE-SPX301
EE-SPX401

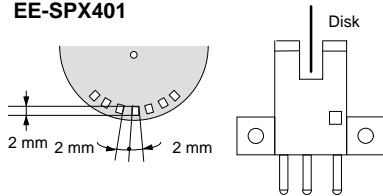

EE-SPY30□
EE-SPY40□

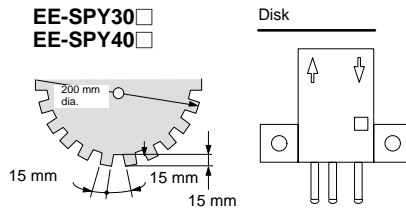

Terminal Arrangement

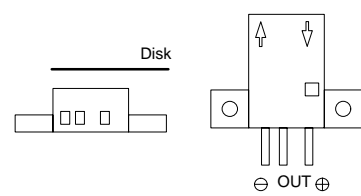

3. Depending on the sensor's immediate environment, it may not function.

■ Characteristics

Ambient illumination	Incandescent light: 3,000 lx max.
Enclosure ratings	IEC IP50
Ambient temperature	Operating: -10° to 55°C Storage: -25° to 65°C
Ambient humidity	Operating: 5% to 85% Storage: 5% to 95%
Vibration resistance	Destruction: 10 to 55 Hz, 1.5-mm double amplitude for 2 hrs each in X, Y, and Z directions
Material	Polycarbonate
Shock resistance	Destruction: 500 m/s ² (approx. 50G) for 3 times each in X, Y, and Z directions
Cable	2 m max. (AWG22 min.)

Engineering Data

Operating Range (Typical)

EE-SPY301, EE-SPY401

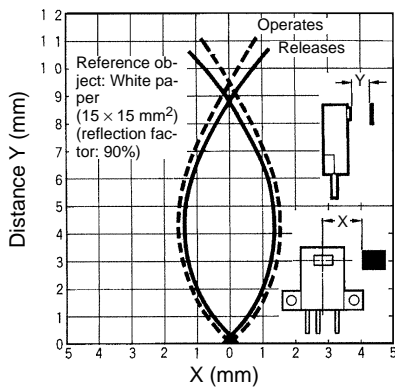

EE-SPY301, EE-SPY401

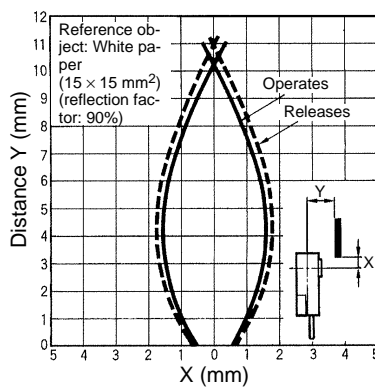

EE-SPY302, EE-SPY402

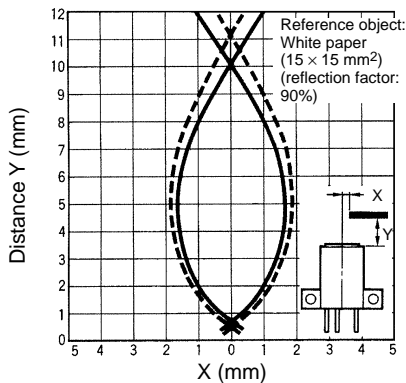

EE-SPY302, EE-SPY402

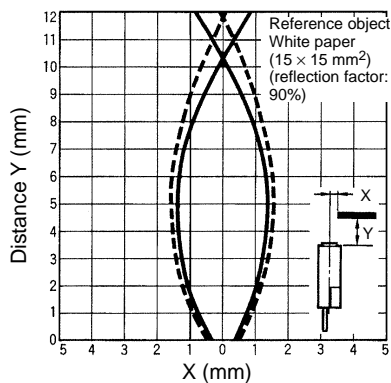

Sensing Distance vs. Object Area (Typical)

EE-SPY□□□□

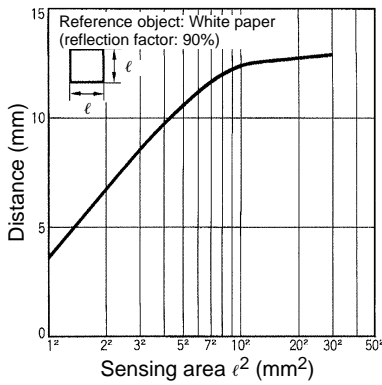

Sensing Position Characteristics (Typical)

EE-SPX301

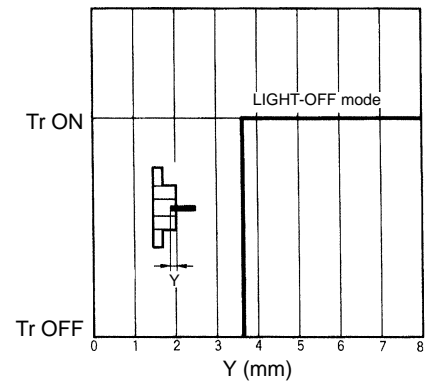
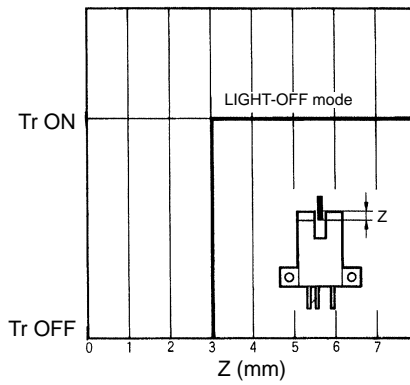

Operating/Reset Distance vs. Cable Length (Typical)

EE-SPY□□□□

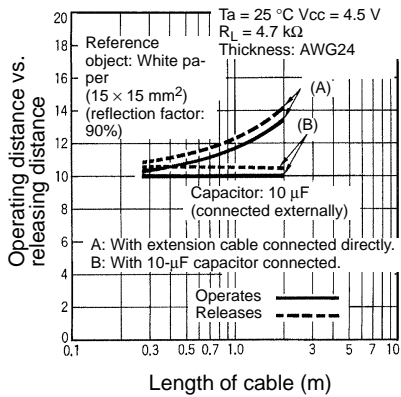

Sensing Angel vs. Sensing Distance (Typical)

EE-SPY□□□□

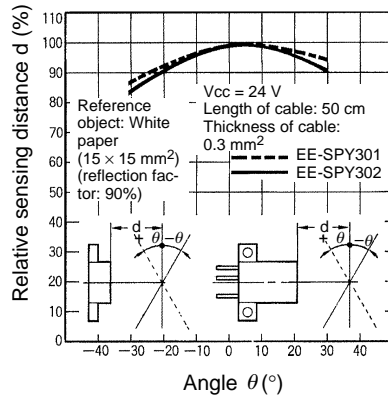

Receiver Output vs. Sensing Distance (Typical)

EE-SPY□□□□

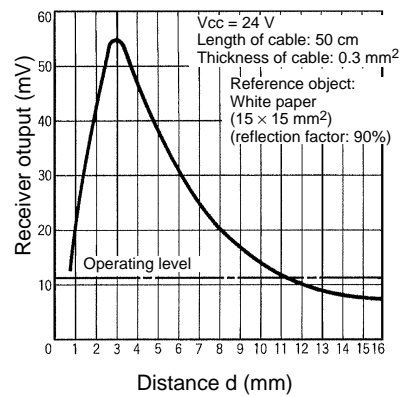

Operation

Output Circuit Diagrams

Light ON/OFF

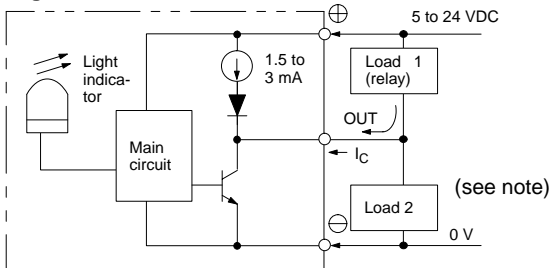

Note: Voltage output (when the sensor is connected to a transistor circuit).

Timing Chart

EE-SPX401, EE-SPY401, EE-SPY402
Light ON

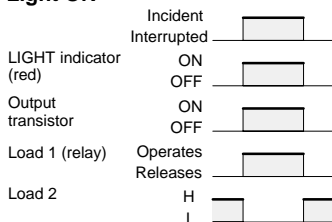

EE-SPX301, EE-SPY301, EE-SPY302
Light OFF

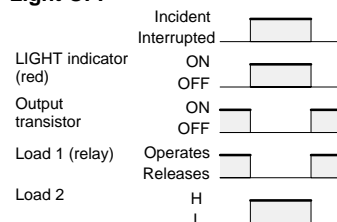

Dimensions

Note: All units are in millimeters unless otherwise indicated.

EE-SPX301
EE-SPX401

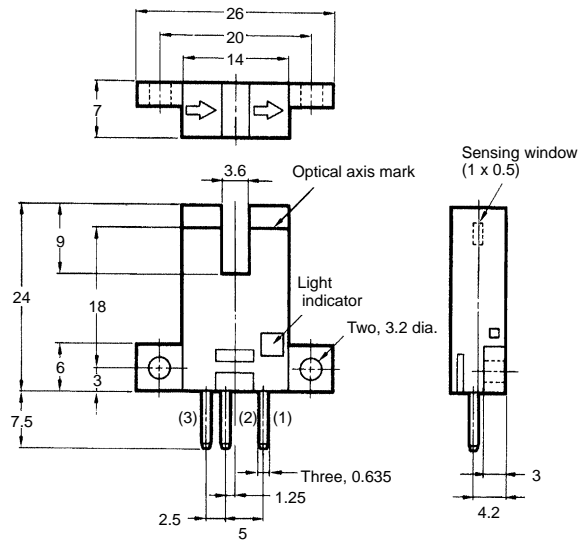
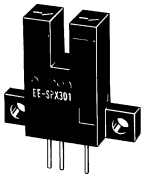

Terminal Arrangement

(1)	⊕	Vcc
(2)	OUT	OUT PUT
(3)	⊖	GND (0 V)

EE-SPY302
EE-SPY402

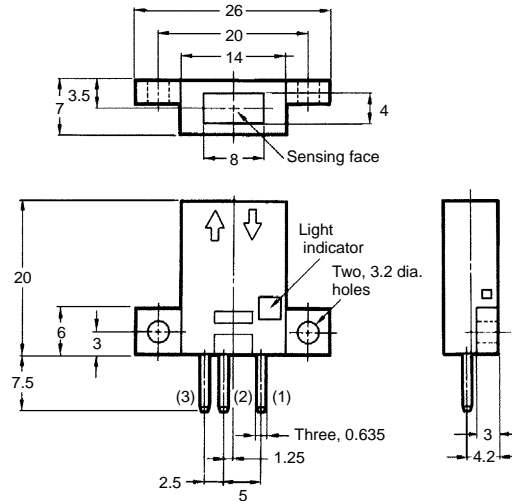
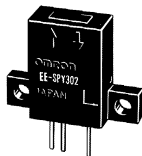

Terminal Arrangement

(1)	⊕	Vcc
(2)	OUT	OUT PUT
(3)	⊖	GND (0 V)

EE-SPY301
EE-SPY401

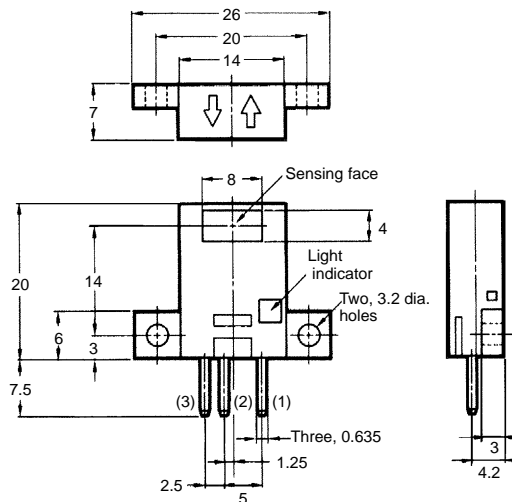
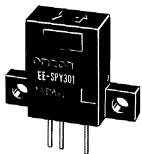

Terminal Arrangement

(1)	⊕	Vcc
(2)	OUT	OUT PUT
(3)	⊖	GND (0 V)

Connector

EE-1002, EE-1003 and EE-1003A. For dimensions refer to page 102.

Precautions

Refer to page 25, *Precautions* in *Technical Information*, for general precautions.

Wiring

Use a cable with a thickness greater than the AWG22 and a length of 2 m max. must be connected to the output terminals.

To use a cable longer than 2 m, attach a capacitor with a capacitance of approximately 10 μ F to the wires as shown below (the distance between the terminal and the capacitor must be within 2 m):

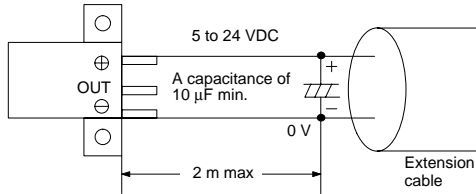

Do not solder the cable to the connectors. Use the EE-1002 Connector or EE-1003 Connector (with a 1-m cable attached) to connect the cable to the output terminals. Use the EE1003A Connector Holder to prevent accidental disconnection of the EE-1003 Connector from the EE-SPY301/401/302/402 Photomicrosensor.

Do not impose excessive force on the terminals (refer to the diagram below). Excess force will damage the terminals.

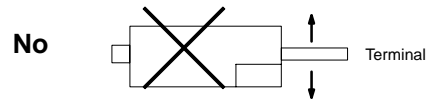

Do not disconnect the EE-1003 Connector from the photomicrosensor when power is supplied to the photomicrosensor or sensor damage could result.

Wire as shown by the following illustration to connect a small inductive load (a relay for example) to the photomicrosensor. A diode must be connected parallel to the relay to absorb the reverse voltage.

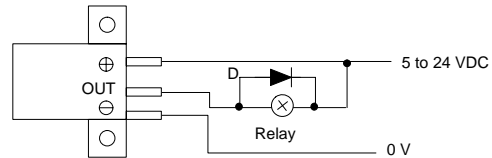

The sensing distance for the EE-SPY Reflective-type Photomicrosensor with built-in amplifier varies from 8 to 20 mm depending on the product (90% reflective white paper). Do not place glossy objects in the background of the sensing object.

ALL DIMENSIONS SHOWN ARE IN MILLIMETERS.
To convert millimeters into inches, multiply by 0.03937. To convert grams into ounces, multiply by 0.03527.