







Miniature Snap Action Switch

- Compact snap action switch with low force operation
- Internal hinge lever mechanism assures outstanding contact reliability



Ordering Information

Actuator	Connect Terminal	OF max.	Part number	
			Rated Current	
			5 A	0.1 A
Pin plunger 	A	25 g	VX-5-1A2	VX-01-1A2
		50 g	VX-5-1A3	VX-01-1A3
	C2	25 g	VX-5-1C22	VX-01-1C22
		50 g	VX-5-1C23	VX-01-1C23
Short hinge lever 	A	50 g	VX-51-1A3	VX-011-1A3
	C2	50 g	VX-51-1C23	VX-011-1C23
Hinge lever 	A	30 g	VX-52-1A3	VX-012-1A3
	C2	30 g	VX-52-1C23	VX-012-1C23
Long hinge lever 	A	15 g	VX-53-1A3	VX-013-1A3
	C2	15 g	VX-53-1C23	VX-013-1C23
Simulated roller lever 	A	30 g	VX-54-1A3	VX-014-1A3
	C2	30 g	VX-54-1C23	VX-014-1C23
Short hinge roller lever 	A	50 g	VX-55-1A3	VX-015-1A3
	C2	50 g	VX-55-1C23	VX-015-1C23
Hinge roller lever 	A	30 g	VX-56-1A3	VX-016-1A3
	C2	30 g	VX-56-1C23	VX-016-1C23

Note: Connect terminal: A -- solder/187 tab common terminal; C2 -- tab terminal (187)

Specifications

■ CHARACTERISTICS

		VX-5	VX-01
Operating speed		0.1 mm to 1 m/second (0.004 to 39.4 in/second) at pin plunger	
Operating frequency	Mechanical	600 operations per minute	
	Electrical	60 operations per minute	
Contact resistance		30 mΩ max.	50 mΩ max.
Insulation resistance		100 MΩ min. at 500 VDC	
Dielectric strength (VAC)		1,000 VAC, 50/60 Hz for 1 minute between non-continuous terminals 1,500 VAC, 50/60 Hz for 1 minute between each terminal and ground	
Vibration (see note 2)	Malfunction durability	10 to 55 Hz, 1.5 mm double amplitude	
Shock (see note 2)	Durability	400 m/s ² min. (approx. 40 g)	
	Malfunction durability	100 m/s ² min. (approx. 10 g)	
Ambient temperature		-25° to 80°C (with no icing)	
Humidity		85% RH max.	
Service life	Mechanical	50,000,000 operations minimum	10,000,000 operations minimum
	Electrical	500,000 operations minimum	1,000,000 operations minimum
Weight		Approx. 6.2 g	

Note: 1. Data shown are of initial value.
2. The values indicated here are of the pin plunger type.

■ OPERATING CHARACTERISTICS

Characteristics	Part number					
	VX-5-1□2	VX-5-1□3	VX-01-1□2	VX-01-1□3	VX-51-1□3	VX-011-1□3
OF max.	25 g	50 g	25 g	50 g	50 g	50 g
RF min.	3 g	5 g	3 g	5 g	4 g	4 g
PT max.	1.2 mm (0.05 in)				1.6 mm (0.06 in)	
OT min.	1.0 mm (0.04 in)				0.8 mm (0.03 in)	
MD max.	0.3 mm (0.01 in)				0.5 mm (0.02 in)	
OP	14.7±0.4 mm (0.58±0.02 in)				15.2±0.5 mm (0.60±0.02 in)	

Characteristics	Part number					
	VX-52-1□3	VX-012-1□3	VX-53-1□3	VX-013-1□3	VX-54-1□3	VX-014-1□3
OF max.	30 g		20 g		60 g	
RF min.	-		-		4 g	
PT max.	4.0 mm (0.16 in)		9.0 mm (0.35 in)		1.6 mm (0.06 in)	
OT min.	1.6 mm (0.06 in)		3.2 mm (0.13 in)		0.8 mm (0.03 in)	
MD max.	0.8 mm (0.03 in)		2.0 mm (0.08 in)		0.5 mm (0.02 in)	
OP	15.2±1.2 mm (0.60±0.05 in)		15.2±2.6 mm (0.60±2.10 in)		20.7±0.6 mm (0.81±0.02 in)	

Characteristics	Part number			
	VX-55-1□3	VX-015-1□3	VX-56-1□3	VX-016-1□3
OF max.	60 g		30 g	
RF min.	4 g		-	
PT max.	1.6 mm (0.06 in)		4.0 mm (0.16 in)	
OT min.	0.8 mm (0.03 in)		1.6 mm (0.06 in)	
MD max.	0.5 mm (0.02 in)		0.8 mm (0.03 in)	
OP	20.7±0.6 mm (0.81±0.02 in)		20.7±1.2 mm (0.81±0.05 in)	

■ RATINGS

Type	Rated load	Non-inductive load (A)				Inductive load (A)			
		Resistive load		Lamp load		Inductive load		Motor load	
		NC	NO	NC	NO	NC	NO	NC	NO
5 A	250 VAC	5	5	0.5	0.5	4	4	—	—
	8 VDC	5	5	3	3	4	4	—	—
	30 VDC	5	5	3	3	4	4	—	—
	125 VDC	0.4	0.4	0.1	0.1	0.4	0.4	—	—
	250 VDC	0.3	0.3	0.05	0.05	0.2	0.2	—	—
0.1 A	125 VAC	0.1	0.1	—	—	—	—	—	—
	8 VDC	0.1	0.1	—	—	—	—	—	—
	30 VDC	0.1	0.1	—	—	—	—	—	—
Inrush current		Standard type (VX-5): 15 A max.				Standard type (VX-5): 15 A max.			

Note: 1. Inductive load has a power factor of 0.4 min. (AC) and a time constant of 7 milliseconds max. (DC).
 2. Lamp load has an inrush current of 10 times the steady-state current, while motor load has an inrush of 6 times the steady-state current.

■ CONTACT FORM

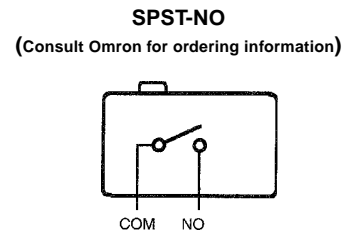
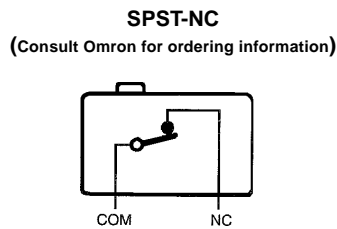
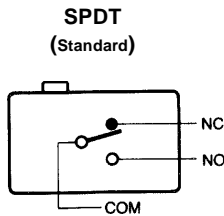

■ APPROVALS

UL (File No. E32667), CSA (File No. LR21642), IEC 1058-1

Rating
5 A, 250 VAC
0.1 A, 125 VAC

Note: The rated values approved by each of the safety standards (e.g. UL, CSA) may be different from the performance characteristics individually defined in this catalog.

Engineering Data

Mechanical service life

VX-5

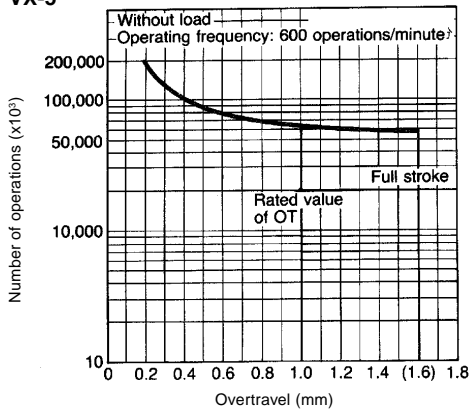

VX-01

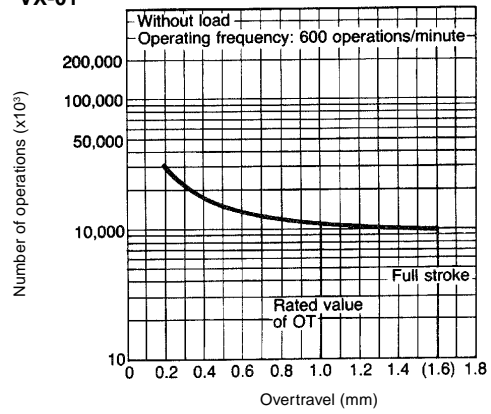

Electrical service life

VX-5

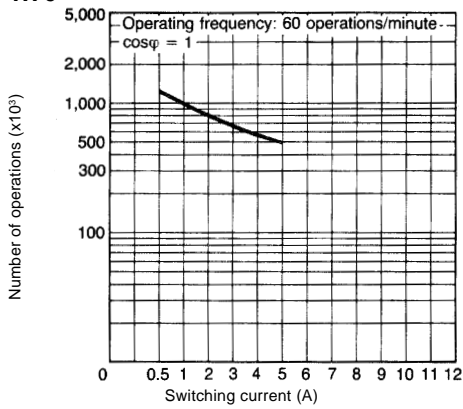

VX-01

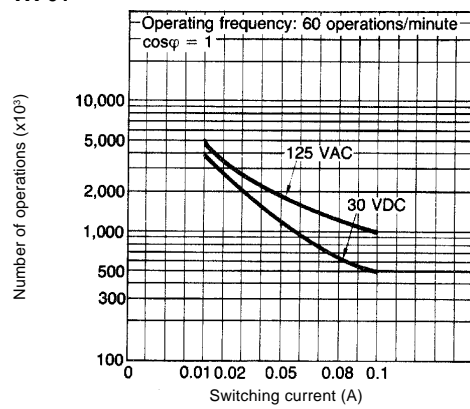

Dimensions

Unit: mm (inch)

■ PIN PLUNGER

VX-5-1□2

VX-5-1□3

VX-01-1□2

VX-01-1□3

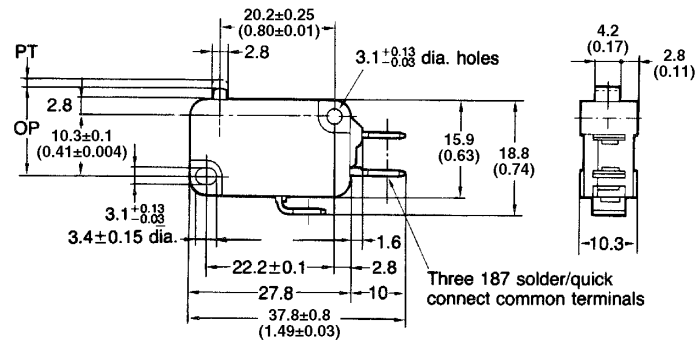

■ SHORT HINGE LEVER

VX-51-1□3

VX-011-1□3

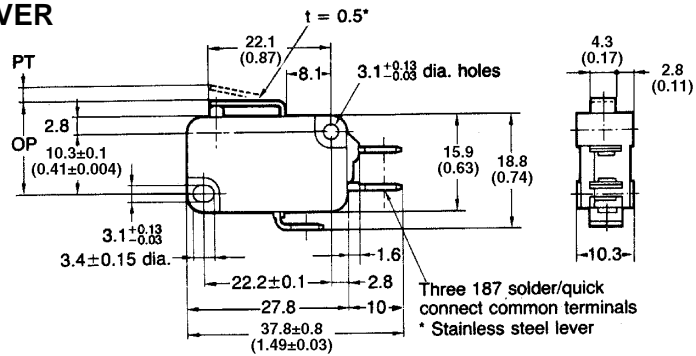

■ HINGE LEVER

VX-52-1□3

VX-012-1□3

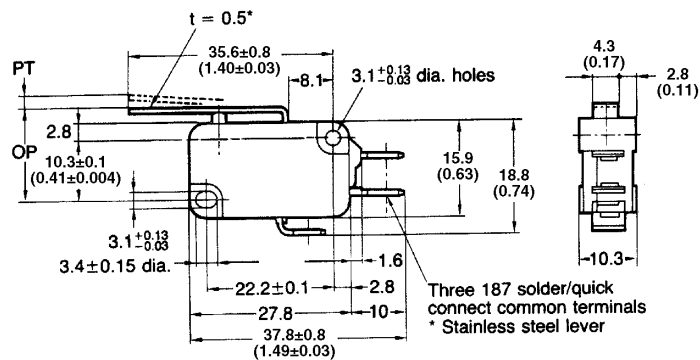

■ LONG HINGE LEVER

VX-53-1□3

VX-013-1□3

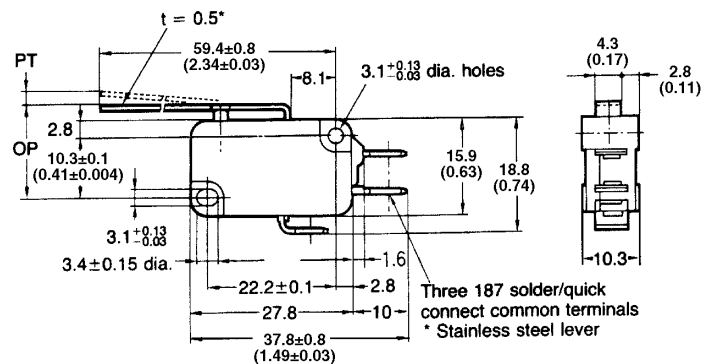

Unit: mm (inch)

■ **SIMULATED ROLLER LEVER**

VX-54-1□3
VX-014-1□3

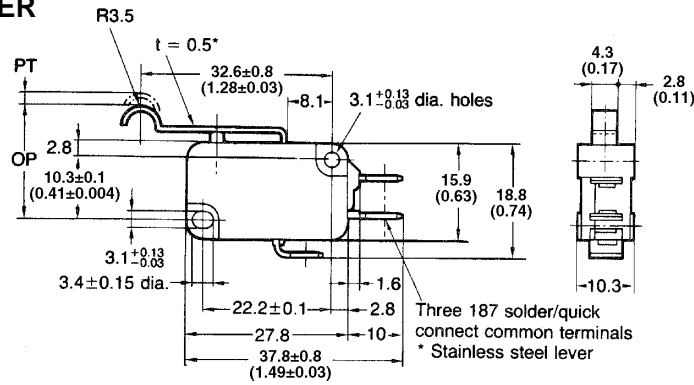

■ **SHORT HINGE ROLLER LEVER**

VX-55-1□3
VX-015-1□3

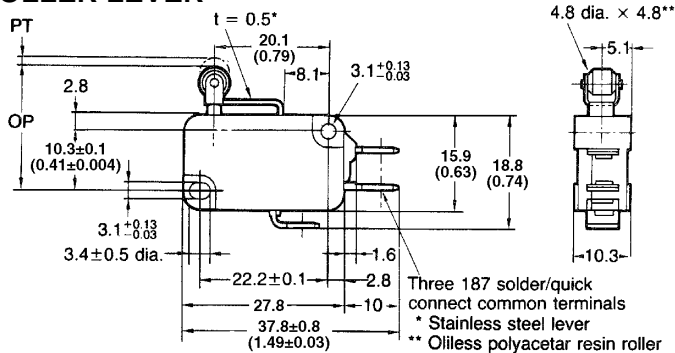

■ **HINGE ROLLER LEVER**

VX-56-1□3
VX-016-1□3

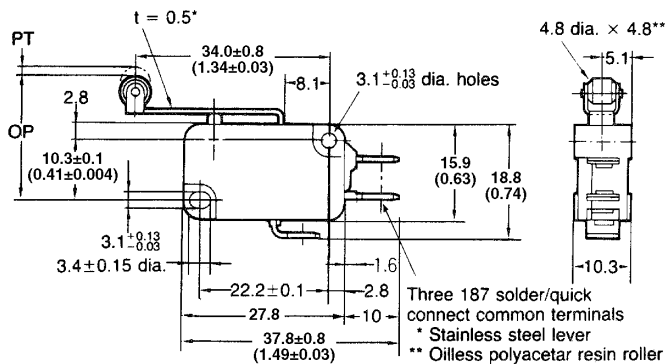

- Note: 1. Unless otherwise specified, a tolerance of ± 0.4 mm applies to all dimensions.
 2. Letters and numbers depend on the type of terminal put in □ shown above.
 A: Solder/quick connect common terminal (187)
 C2: Quick connect terminal (187)
 3. For smaller mounting holes, please consult OMRON.

■ TERMINALS

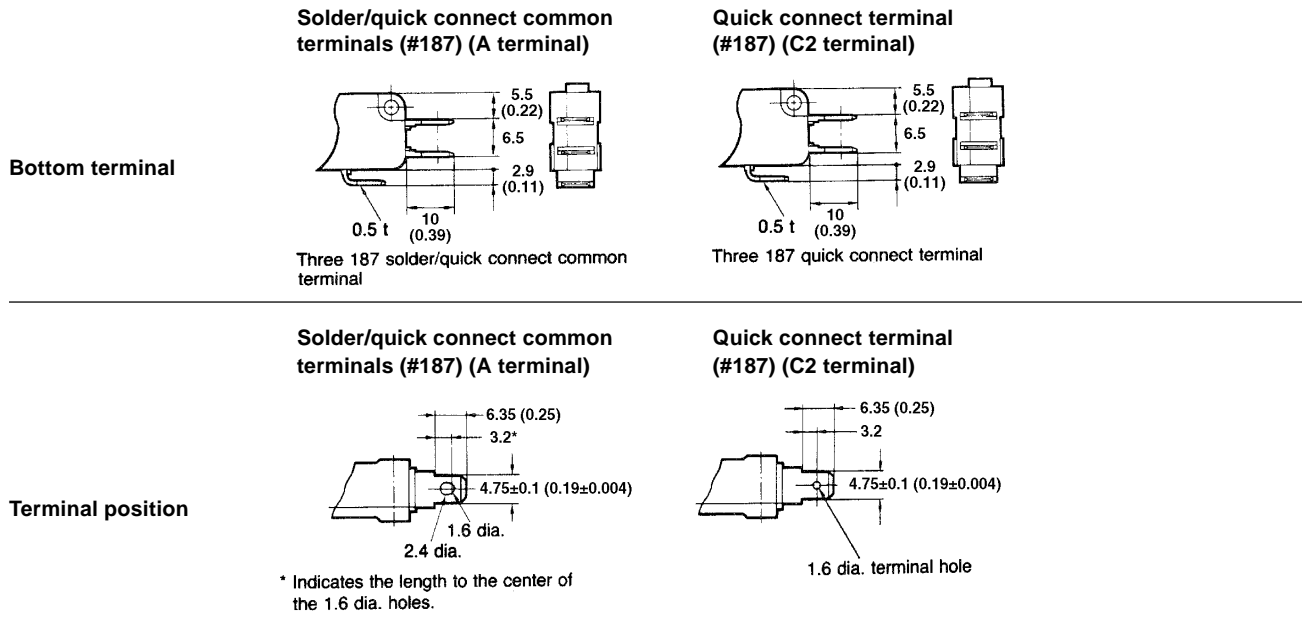

Precautions

■ MOUNTING

Mount the switch by tightening the two M3 screws with a matching driver, using appropriate torque (4 to 6 kg-cm).

Switch protection

Do not use where there are toxic gases (such as near an oil-burning stove), nor in a dusty or humid environment.

Depending on environmental conditions, the switch should be rechecked about 3 to 6 months after it has been assembled.

Mounting hole dimensions

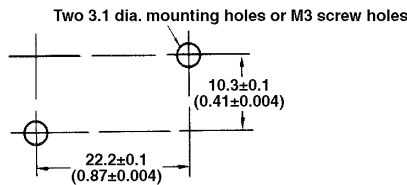

Quickly finish the soldering of the lead wire to its terminal. Use a soldering iron rated at 60W and preferably complete the soldering within 5 seconds.

Excess wattage or prolonged heating can deteriorate the characteristics of the switch.

When mounting, make sure there is sufficient insulation distance between the switch and its mounting panel. If it is insufficient, install an insulation guard or separator. Always install an insulation guard or separator when mounting the microswitch on a metallic body. Contact your OMRON representative for information about insulation guards and separators.

■ OPERATION

Keep the operation control completely separate from the actuator of the switch, and push it down fully when starting operation. Do not displace the operating position of the actuator when machining.

Consult OMRON in advance if the operating speed is to be extremely slow, or if the pushbutton is to be set somewhere between the free position and operating position.

Mount pin pushbutton switches so that stroke of the pushbutton and the stroke of the operating control overlap on a vertical line. The stroke of the switch, after operation, should be set to 60-90% that of standard OT (MIN operation).

NOTE: DIMENSIONS ARE SHOWN IN MILLIMETERS. To convert millimeters to inches divide by 25.4.

OMRON**OMRON ELECTRONICS LLC.**

One East Commerce Drive
Schaumburg, IL 60173

1-800-55-OMRON**OMRON ON-LINE**

Global - <http://www.omron.com>
USA - <http://www.omron.com/oei>
Canada - <http://www.omron.com/oci>

OMRON CANADA, INC.

885 Milner Avenue
Scarborough, Ontario M1B 5V8
416-286-6465